

SINGLE PHASE INDUSTRIAL CONTROL TRANSFORMERS - 4 kVA TO 50 kVA

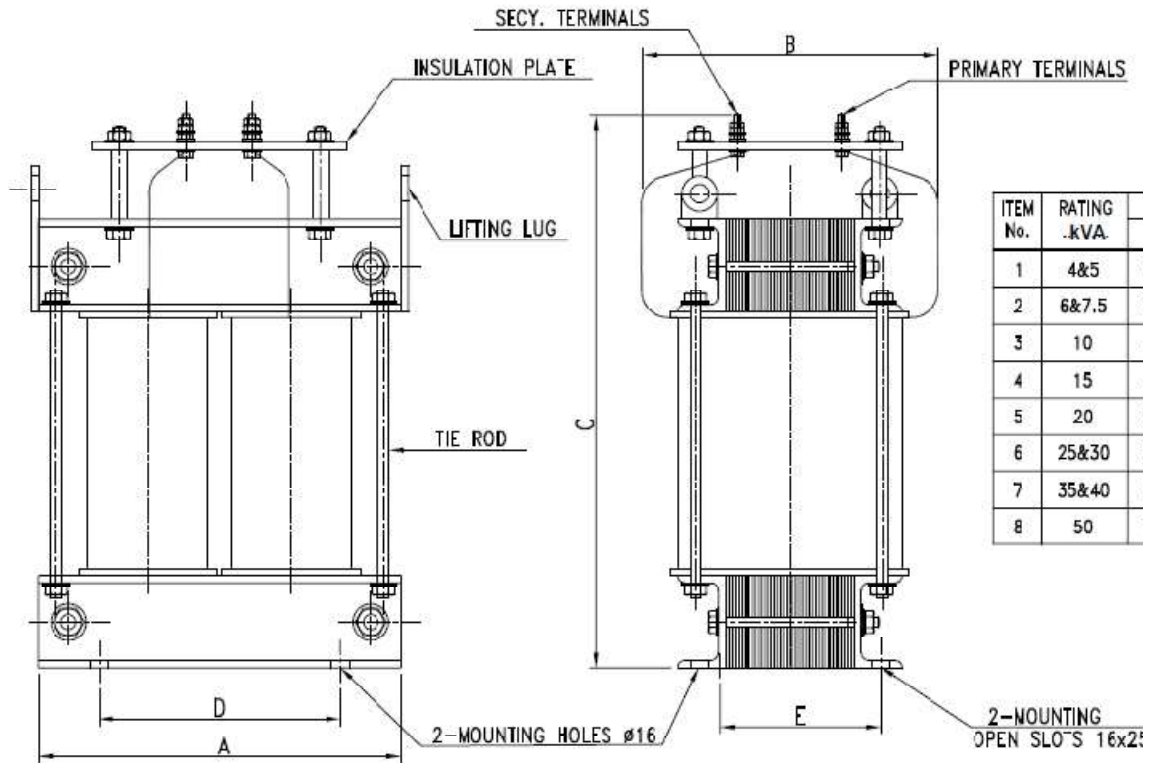

NOTES:

1. GEN. TOLERANCE : ± 5 mm
2. PREFERRED RATED PRIMARY VOLTAGE : 110V, 240V & 415V.
3. PREFERRED RATED SECONDARY VOLTAGE : 110V & 240V.
4. DIMENSIONS MAY VARY FROM THOSE GIVEN ABOVE IF VOLTAGES ARE OTHER THAN PREFERRED VALUES.
5. TIE RODS & LIFTING LUGS ARE PROVIDED FOR RATING ABOVE 10KVA ONLY.
6. TERMINAL BLOCKS ARE PROVIDED FOR RATINGS UPTO 15 kVA
7. TERMINAL SHROUD PROVIDED FOR HIGHER RATINGS ON REQUEST ONLY.

TABLE OF DIMENSIONS

Item no	Rating in VA	A mm	Bmm	C mm	Dmm	E mm	Weight(Kgs)
1	4&5	300	240	450	200	150	65
2	6&7.5	350	260	500	250	150	82
3	10	400	280	550	300	150	95
4	15	450	300	625	380	150	120
5	20	500	350	675	380	165	135
6	25&30	575	375	725	500	175	160
7	35&40	650	400	750	500	195	185
8	50	700	450	875	550	195	210